

UNIT WEIGHT:
APPROX. 11,000 LBS.

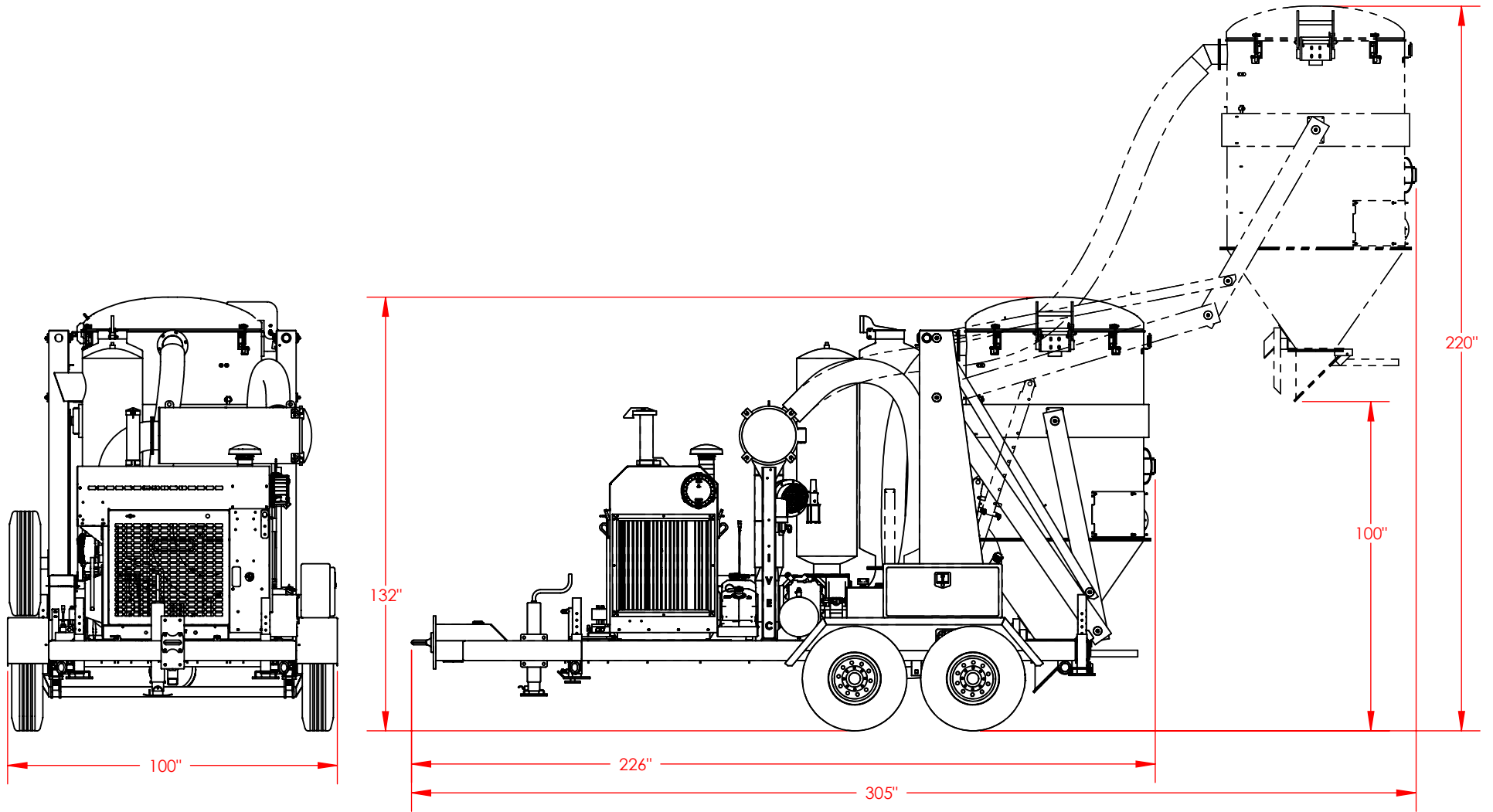

HURRICANE TRAILER 500 DIESEL

INDUSTRIAL VACUUM
EQUIPMENT CORP.



DRW BY: C.J.G. DRW DATE: 4/5/19
REV: REV DATE:

PROPRIETARY AND CONFIDENTIAL

THE INFORMATION CONTAINED IN THIS DRAWING IS THE SOLE PROPERTY OF INDUSTRIAL VACUUM EQUIPMENT CORP. ANY REPRODUCTION IN PART OR AS A WHOLE WITHOUT THE WRITTEN PERMISSION OF INDUSTRIAL VACUUM EQUIPMENT CORP. IS PROHIBITED.

DRW/PRT NAME: OVERALL DIMENSIONS

SERIES: HURRICANE TRAILER

MODEL: HT500

SHEET 1 OF 3

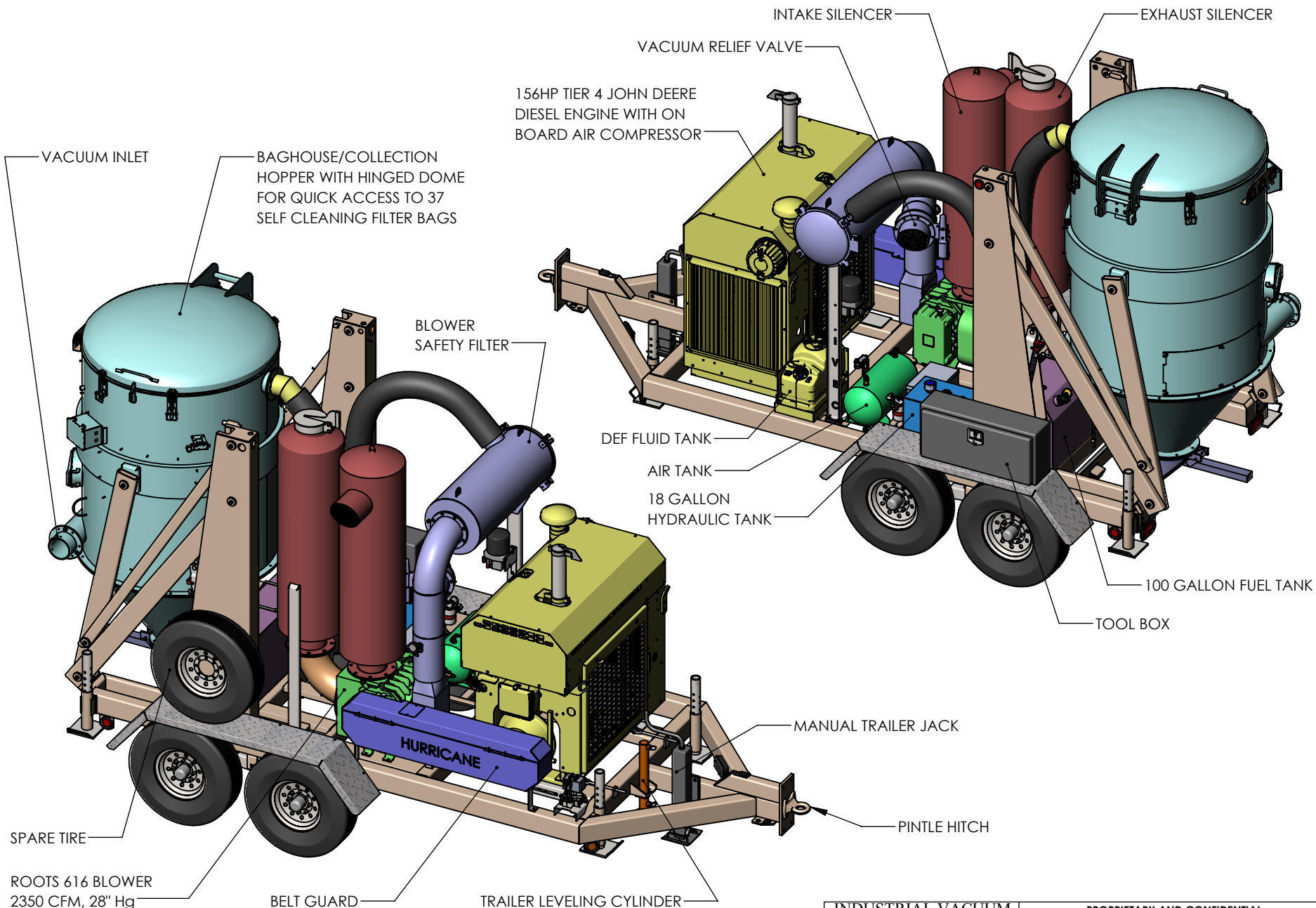

HURRICANE TRAILER 500 DIESEL

INDUSTRIAL VACUUM EQUIPMENT CORP.		PROPRIETARY AND CONFIDENTIAL	
		THE INFORMATION CONTAINED IN THIS DRAWING IS THE SOLE PROPERTY OF INDUSTRIAL VACUUM EQUIPMENT CORP. ANY REPRODUCTION IN PART OR AS A WHOLE WITHOUT THE WRITTEN PERMISSION OF INDUSTRIAL VACUUM EQUIPMENT CORP. IS PROHIBITED.	
		DRW/PRT NAME: COMPONENT CALLOUTS	
DRW BY: CJG		SERIES: HURRICANE TRAILER	
DRW DATE: 4/5/19		MODEL: HT500	
REV:		SHEET 2 OF 3	

KEY



AIR & MATERIAL FLOW



AIR FLOW



MATERIAL FLOW

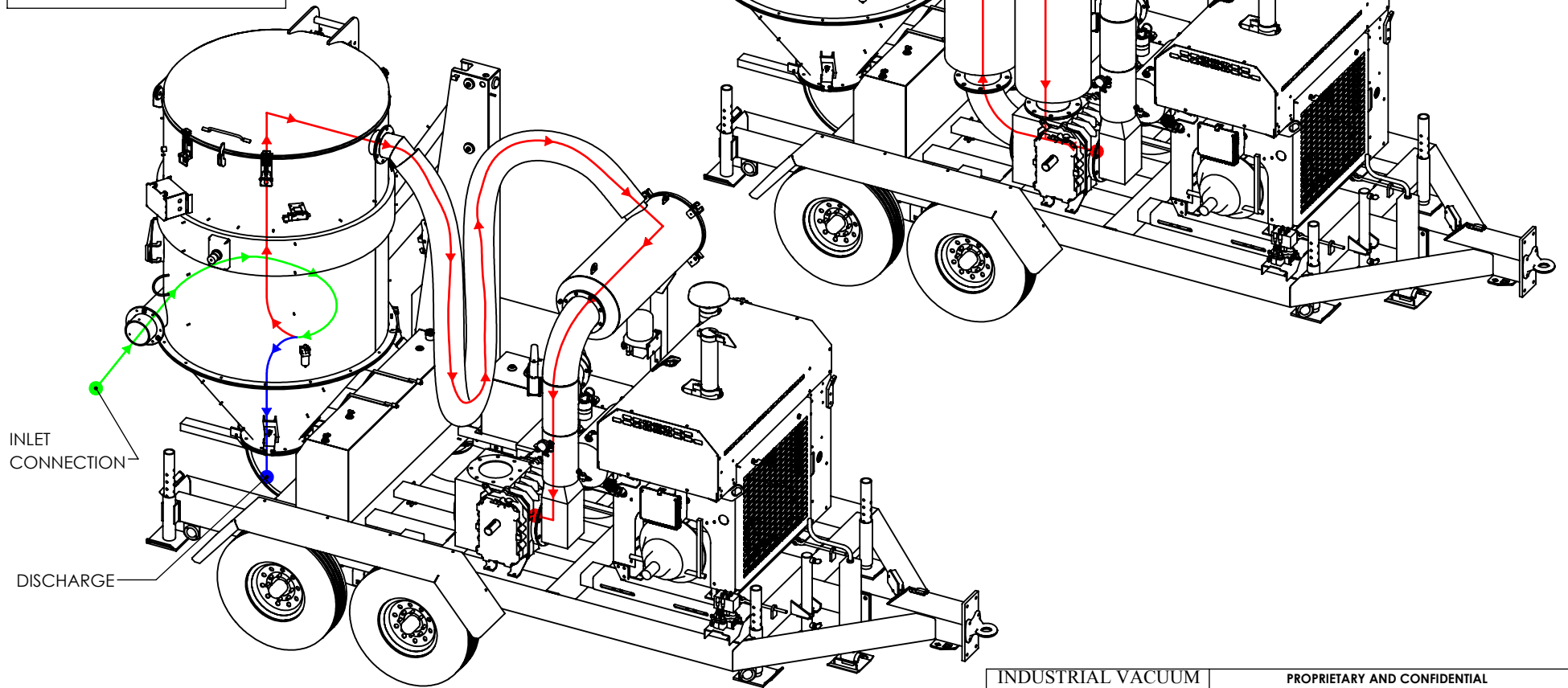

HURRICANE TRAILER 500 DIESEL

INDUSTRIAL VACUUM
EQUIPMENT CORP.



DRW BY: CJG DRW DATE: 4/5/19
REV: REV DATE:

PROPRIETARY AND CONFIDENTIAL

THE INFORMATION CONTAINED IN THIS DRAWING IS THE SOLE PROPERTY OF INDUSTRIAL VACUUM EQUIPMENT CORP. ANY REPRODUCTION IN PART OR AS A WHOLE WITHOUT THE WRITTEN PERMISSION OF INDUSTRIAL VACUUM EQUIPMENT CORP. IS PROHIBITED.

DRW/PRT NAME: FLOW DIAGRAM

SERIES: HURRICANE TRAILER

MODEL: HT500

SHEET 3 OF 3