

PORTABLE DUST COLLECTOR SYSTEM 2500 PDC DUST CYCLONE MODEL

OPERATION'S MANUAL



INDUSTRIAL VACUUM EQUIPMENT CORP.
N7959 BIRCH RD.
IXONIA, WI 53036
www.industrialvacuum.com

**REVIEW THIS MANUAL BEFORE OPERATING THE
PORTABLE DUST COLLECTOR SYSTEM**

TABLE OF CONTENTS

SECTION 1:

GENERAL INFORMATION AND INSTALLATION INSTRUCTIONS

- 1.1 IMPORTANT SAFETY PRECAUTIONS AND WARNINGS
- 1.2 EQUIPMENT VIEW AND IDENTIFICATION
- 1.3 INSPECTION OF EQUIPMENT
- 1.4 SETTING UP THE PORTABLE DUST COLLECTOR SYSTEM
- 1.5 CONNECTING AIR SUPPLY

SECTION 2:

OPERATION AND SHUTDOWN INSTRUCTIONS

- 2.1 INITIAL START-UP PROCEDURE
- 2.2 OPERATING THE PORTABLE DUST COLLECTOR SYSTEM
- 2.3 SHUT DOWN PROCEDURE

SECTION 3:

MAINTENANCE AND TROUBLESHOOTING INSTRUCTIONS

- 3.1 ROUTINE MAINTENANCE
- 3.2 MAINTENANCE SCHEDULE
- 3.3 FILTER REMOVAL AND INSTALLATION
- 3.4 TROUBLE SHOOTING
- 3.5 TECHNICAL SUPPORT AND CONTACT INFORMATION

SECTION 4:

SPECIFICATIONS AND OPTIONAL EQUIPMENT

- 4.1 EQUIPMENT DATA
- 4.2 OPTIONAL ACCESSORIES

SECTION 5:

MAJOR COMPONENTS AND REFERENCE INFORMATION

- 5.1 MOTOR
- 5.2 CENTRIFUGAL FAN

SECTION 6:

WARRANTY AND SERVICE NOTES

SECTION 7:

SPARE PARTS LIST

SECTION 8:

DIAGRAMS AND SCHEMATICS

IMPORTANT SAFETY PRECAUTIONS AND WARNINGS!

When using the Portable Dust Collector System, always follow basic safety precautions, including but not limited to the following:

WARNING! This symbol appears when a potentially hazardous safety condition exists that could cause personal injury or death. These hazards are not always apparent to even the most trained mechanics.

WARNING! It is recommended that ALL owners/operators and personnel working around or with The Portable Dust Collector System read and understand this manual BEFORE operating the equipment.



WARNING! ONLY authorized and trained personnel should operate this equipment.

WARNING! This manual should be kept near The Portable Dust Collector System for future referencing.

WARNING! ALWAYS use Proper Protective Equipment (PPE) when operating or working near The Portable Dust Collector System. Protective footwear, hearing protection, and safety glasses are recommended, but not limited to, during operations.



*** ALWAYS following OSHA's
State and Federal Guidelines.

WARNING! Read and follow all safety decals located on the equipment. Keep in good condition. Replace damaged or missing decals accordingly. Replacements are available from manufacturer.

WARNING! ALWAYS be prepared for emergencies! Have phone numbers and first aid items readily available and know your company's designated Emergency Action Plan.

WARNING! NEVER start or operate this equipment without the proper safety guards or protective parts in place. Failure to do so could cause serious personal injury, death, and/or property damage.

WARNING! ALWAYS disconnect and lockout-tag out power BEFORE servicing or performing any and all maintenance on The Portable Dust Collector Equipment. Failure to do so could result in serious personal injury, death and/or property damage.



WARNING! Use caution while transporting equipment, making sure this equipment, its components, and any attachments are secured properly **BEFORE** transporting.

WARNING! Use caution while bringing this equipment into the desired work area. Go slow, stay alert. Watch out for personnel, potential surrounding hazards and environmental changes.

WARNING! When setting up for operations, make sure the unit is set-up on a solid level surface. If surface conditions are not level or solid, take proper precautions with planks or plywood for a more secure and safe work area.

WARNING! Wheel Cart locking casters are considered a pinch point, use caution when locking or unlocking.



WARNING! NEVER lift or transport The Portable Dust Collector System with the Cyclonic Separator full.

WARNING! The Portable Dust Collector System should ONLY be lifted or transported while the Cyclonic Separator is EMPTY.

WARNING! NEVER open the Cyclonic Separator's access doors while the equipment is operating. Failure to keep doors close could cause serious personal injury.

WARNING! Cyclonic Separator and Filters alike may contain harmful materials. Take the proper steps and precautions to clean, dispose or change the filter media. Use Proper Protective Safety Equipment (PPE), it is recommended to wear a respirator while working with filters, in the Cyclonic Separator enclosure, or in/around the collection/discharge area.

***** ALWAYS following OSHA's State and Federal Guidelines.**

WARNING! NEVER enter the Cyclonic Separator Enclosure without disconnecting all power and following proper lockout-tag out procedures PRIOR to servicing or performing any and all maintenance.

WARNING! The Cyclonic Separator Enclosure is considered a Confined Space Hazard, NEVER enter without disconnecting all power and following proper lockout-tag out procedures PRIOR to entering. It is recommended, to always tell and have someone at the opening in case of injuries inside space.

WARNING! ALWAYS empty the Cyclonic Separator after operations, taking the proper steps and precautions to clean out and dispose of the waste.

***** ALWAYS following OSHA's State and Federal guidelines.**

WARNING! It is recommended to work in well- ventilated areas.

WARNING! DO NOT use the Portable Dust Collector System on explosive materials and/or gases.

***ALWAYS following OSHA's State and Federal guidelines.

WARNING! This equipment utilizes electricity, use caution. Electric shock can cause serious personal injury, death and/or property damage

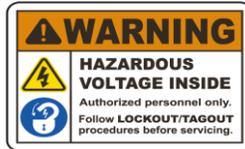

WARNING! ALWAYS disconnect the power source before servicing the electrical. High voltage can cause severe personal injury, death and/or property damage.

WARNING! Fans are designed to work by creating suction and air pressure which can be hazardous. NEVER stand directly in front of the inlet(s) and/or outlet(s) while unit is on and operating.

- **Inlet-** Is an opening or entrance for intake. Personnel or solid objects in close proximity to a fan inlet can be overcome by the created intake suction, and drawn into the fan.
- **Outlet-** Is an opening, or exit through which something is let out. Personnel in close proximity to a fan outlet can be subject to debris become dangerous projectiles upon being exhausted out.

WARNING! Never operate, service, perform maintenance, or attempt to touch fan with guards removed. Fan blade can cause serious personal injury, death and/or property damage.



WARNING! NEVER operate the fan with a non-ducted inlet and/or outlet. If the blower inlet and/or outlet is non-ducted, it is the user's responsibility to install an inlet and/or outlet guard.

WARNING! Even when the power supply is locked out, fans may cause injury or damage if the impeller is subject to "wind-milling," which is the fan blade and drive components turning due to a draft system. To guard against this hazard, secure fan blade, allowing no rotational movement.

WARNING! Components on this equipment, such as but not limited to, engine pipes and engine muffler can burn you. Stay away if engine has been running. WAIT for engine to cool down prior to servicing or any routine maintenance. Hot Components can cause serious personal injury.



WARNING! California Proposition 65 Warning –Engine Exhaust and some of its constituents from this product are known to the State of California to cause cancer, birth defects and other reproductive harm.



WARNING! Carbon Monoxide Gas can be FATAL!!! The engine emits toxic poisonous Carbon Monoxide Gas. Carbon Monoxide gas is a colorless, odorless gas that is generated whenever internal combustion engines are operating. Prolonged inhalation of air contaminated with only a small percentage of carbon monoxide gas may cause injury or death. DO NOT run in an enclosed area.

WARNING! Work in well-ventilated areas and DO NOT use this equipment on explosive materials and/or gases.

WARNING! Gasoline is highly flammable and explosive. Turn engine off and allow to cool before refueling.



WARNING! It is recommended to use caution by wearing an appropriate mask/respirator whenever working with, near, or around Dust.



WARNING! It is recommended to wear a respirator whenever working with The Portable Dust Collector's used filters, or inside a dirty hopper. ****NEVER** open filter enclosure doors while unit is running. Lockout-Tagout prior to adjusting, servicing, cleaning, and or performing maintenance to the Filter Cartridges or inside a dirty hopper. **

WARNING! When lifting, ALWAYS remember to use proper Safe Lifting Techniques.

Safe Lifting Recommendations

- Bend at your knees, not at the waist.
- Keep your Back Straight.
- Keep object close to body and while maintaining a good grip.
- Don't lift and twist: always turn your feet, never twist you back.
- Ask for or get help if the load is too large and/or heavy.



THIS MANUAL SHOULD BE KEPT NEAR THE PORTABLE DUST COLLECTOR SYSTEM FOR FUTURE REFERENCE.

SAVE THESE INSTRUCTIONS!!!

1.2 EQUIPMENT VIEW AND IDENTIFICATION

SPECIAL INFORMATION ABOUT THE PORTABLE DUST COLLECTOR SYSTEM

Each Portable Dust Collector (PDC) is built with standard equipment options, but also can be built with specific customized features. Therefore, some of the information described in this manual may not apply to your particular equipment.

Portable Dust Collector System:

Model: 2500 PDC Model

Serial: PDC-0011

This equipment weighs 1400 lbs. Caution must be used in lifting and transporting.

This equipment is 6'-6" in height. Caution must be used during transportation.

This unit has the following Customized Features:

- Standard Equipment Options
 - 8.9 HP Gasoline Honda Engine, Direct Drive
 - 2500 CFM @ 8" SP Cincinnati Blower, HDBI-120 Fan
 - 12VDC, 5.3CFM Heavy Duty Air Compressor
 - (2) UX NANA Fiber Media, Fire Retardant, MERV 15
 - (1) Carbon Odor Exhaust Filter
 - (1) Stainless Steel Filter, Spark Arrestor – with Washable Metal Mesh
 - Manual Push Button Cartridge Pulse Jet Cleaning
 - 22" Dia. Cyclone Separator, 55-Gallon Drum
 - (2) Lockable Swivel Caster Wheels
 - (2) Rigid Caster Wheels
 - Dust & Debris Drawer
 - Magnehelic Gauge
 - Epoxy Primer and Polyurethane Enamel Top Coat
 - 12 Gauge Carbon Steel Construction
-

1.2 EQUIPMENT VIEW AND IDENTIFICATION



<u>Key</u>	<u>Identification</u>	<u>Remarks</u>
A	8.9 HP Honda Engine	Unleaded – Pump Octane Rating 86 or Higher
B	Fresh Air Exhaust	
C	Fan	HDBI-120, 2500 CFM @ 8" SP
D	Instrument Panel	
E	22" Dia. Cyclone Separator	
F	Lockable Hinged Filter Enclosure Access Door	
G	Adjustable Drum Cover with Locking Handles	
H	On-Board Air Compressor	
I	55-Gallon Drum	
J	Lockable Swivel Caster Wheels	(2)
K	Rigid Caster Wheels	(2)

1.2 EQUIPMENT VIEW AND IDENTIFICATION



Key	Identification	Remarks
A	8" Hose Inlet Connection	Optional 6" Hose Inlet Connection
B	22" Dia. Cyclone Separator	
C	Air Tank	80- PSI Max
D	8.9HP, Honda Gasoline Engine	
E	Fan	HDBI-120, 2500 CFM @ 8" SP
F	Fresh Air Exhaust	
G	Push Handle	
H	55-Gallon Drum	
I	Filter Enclosure	
J	Rigid Caster Wheels	(2)
K	Lockable Swivel Caster Wheels	(2)

1.2 EQUIPMENT VIEW AND IDENTIFICATION
(Instrument Panel)



<u>Key</u>	<u>Identification</u>	<u>Remarks</u>
A	Magnehelic Gauge	Check filters when Indicator Reaches 4
B	Air Pressure Gauge	80 – PSI Max.
C	Filter Pulsing Button	PUSH to Pulse Filters
D	Key Ignition Switch	OFF/ON/START
E	Air Compressor Switch	ON/OFF
F	Choke/ Throttle Control Knob	

1.2 EQUIPMENT VIEW AND IDENTIFICATION (Engine Close- Up)

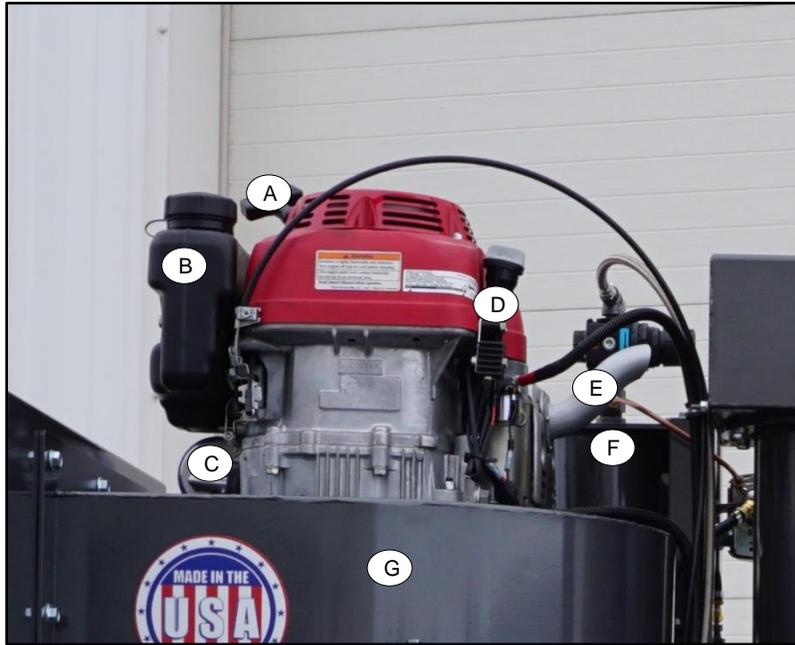

Key	Identification	Remarks
A	Engine Pull Start	
B	Gas Tank	Unleaded- Pump Octane Rating 86 or Higher
C	Oil Filter	SAE 10W-30 Recommended for General Use
D	Oil Dip Stick	
E	Engine Exhaust	
F	Air Tank	80 – PSI Max.
G	Fan	HDBI-120, 2500 CFM @ 8" SP

1.2 EQUIPMENT VIEW AND IDENTIFICATION
(Filter Cartridge Enclosure)



<u>Key</u>	<u>Identification</u>	<u>Remarks</u>
A	Filter Cartridge	(2) UX Nana Fiber Media, Fire Retardant, MERV 15
B	Stainless Steel Spark Arrestor Filter	Metal Mesh Washable Prefilter
C	Filter Engagement Handle	LIFT-UP when Removing Any Filter
D	Dust and Debris Drawer	Removable

1.3 INSPECTION OF EQUIPMENT

Please inspect the equipment for proper parts, orientation, size, and condition prior to accepting shipment.

Notify the manufacturer immediately if there are any concerns in the equipment that you are receiving.

The Portable Dust Collector System should be transported with the appropriate vehicle that can handle the size and weight.

Check Prior to Transporting:

- Equipment should be off
- Discharge Drum should be emptied and adjustable drum cover locked down on drum.
- All hose connection inlets should be covered and secured using the provided clamps. Secure duct hose on the trailer or in a separate hose storage area.

During transportation caution must be used when going under, bridges, walkways or other overhead clearances. This equipment is 6'-6" in height.

1.4 SETTING UP THE PORTABLE DUST COLLECTOR SYSTEM

The Portable Dust Collector System offers a modular design with a cyclonic separator, heavy-duty steel, compact and durable. Designed for applications demanding portable equipment in hard to reach or remote locations.

The equipment should be set up in an area where the ground is solid and level. If necessary, make appropriate accommodations so the work area will be safe and secure. Using planks and/or plywood can help with creating a sturdier and level work area.

It is recommended that work area must be clean and clear for good visibility and footing to prevent tripping hazards.

- Upon arrival of Equipment, Lift the unit with a forklift or crane that is rated and capable of lifting the weight of The Portable Dust Collector System off the transporting trailer. Setting down in desired work area.
- The Wheel Locking Casters will need to be unlocked if equipment needs to be moved. Equipment should be moved using push handle. GO SLOW!

**** Use Caution when adjusting the locking casters. Keep hands and fingers clear of Pinch Point Hazards. Pinch Points can cause serious personal injury.**



**** Use Caution while moving this equipment, be aware of personnel, the surrounding area, and potential obstructions in your path.**

- Attach the appropriate size duct hose to the inlet connection(s).
- Once at desired work area, lock The Wheel Locking Casters.
- Install 55-Gallon drum under the Cyclonic Separator.
USE CAUTION WHEN SWITCHING 55-GALLON DRUMS OUT
- Make sure the 55-Gallon drum is attached to the Cyclonic Separator
- When 55-Gallon drum is lined up to the Cyclonic Separator, PULL the drum cover handle(s) there are two (2) and pull up the latching mechanism/ safety catch so the lid can lower down and lock on the drum opening.

Drum Cover Locking Handle:

Shown "UP in LOCKED" position.



Shown "DOWN in UNLOCKED" position.



1.5 CONNECTING AIR SUPPLY

Customer supplied hook-up connection: (Needed for equipment without an onboard air compressor package)

The compressed air supply line should be a minimum of 3/8" diameter or a recommended 1/2" diameter rated for the PSI that is being supplied from the compressor source. The airline must be free of dirt, oil, and water. Purging the airline prior to installation is recommended.

A clean, dry and oil-free air supply is required for proper operation. The air will need to be regulated at 80-PSI max. (regulator with the unit). If excessive moisture is present in the air system, an after cooler, desiccant dryer and in line air filter are strongly recommended.

The air inlet plug is located in the back, by the fresh air exhaust and unit push handle.



SECTION 2: OPERATION AND SHUTDOWN INSTRUCTIONS

2.1 INITIAL START-UP PROCEDURES

The following procedures need to be followed prior to operating The Portable Dust Collector System. Refer to these sections:

- SECTION 1.4 SETTING UP THE PORTABLE DUST COLLECTOR SYSTEM
- SECTION 1.6 CONNECTING AIR SUPPLY

Initial Set-Up:

The operation of the system needs to be checked. Make sure the electrical outlet that will run The Portable Dust Collector System has power. The following steps will need to be verified:

- Check to see that Inlet/Outlet Hose Connections are securely attached.
 - Be sure there is nothing that could block or obstruct the Inlet/Outlet hoses.
 - Double Check the Wheel Locking Casters are secured into the "LOCKED" position.
 - Check the Engine Oil. Oil type SAE 10W-30 is recommended for general use.
 - Make sure there is gas. Recommended gas type is unleaded gas – pump octane rating 86 or higher.
 - The Portable Dust Collector System is now set-up and ready for operations.
-

2.2 OPERATING THE PORTABLE DUST COLLECTOR SYSTEM

This Equipment can be used in applications as both a utility collector and for general ventilation. The Portable Dust Collector System is capable of many types of dust and fume collection.

The Portable Dust Collector System offers a modular design with a cyclonic separator, heavy-duty steel, compact and durable. Designed for applications demanding portable equipment in hard to reach or remote locations.

During Equipment operations, the fan works by creating suction and air pressure; pulling air into the inlet, and pushing or exhausting air out at the outlet. Throughout this process the Portable Dust Collector System also collects the particles in the air, filters that air in a recirculation process.

WARNING! Fans are designed to work by creating suction and air pressure which can be hazardous. NEVER stand directly in front of the inlet(s) and/or outlet(s) while unit is on and operating.

- **Inlet-** Is an opening or entrance for intake. Personnel or solid objects in close proximity to a fan inlet can be overcome by the created intake suction, and drawn into the fan.
- **Outlet-** Is an opening, or exit through which something is let out. Personnel in close proximity to a fan outlet can be subject to debris become dangerous projectiles upon being exhausted out.

WARNING! Never operate, service, perform maintenance, or attempt to touch fan with guards removed. Fan blade can cause serious personal injury, death and/or property damage.



WARNING! NEVER operate the fan with a non-ducted inlet and/or outlet. If the blower inlet and/or outlet is non-ducted, it is the user's responsibility to install an inlet and/or outlet guard.

WARNING! Even when the power supply is locked out, fans may cause injury or damage if the impeller is subject to "wind-milling," which is the fan blade and drive components turning due to a draft system. To guard against this hazard, secure fan blade, allowing no rotational movement.

WARNING! Cyclonic Separator and Filters alike may contain harmful materials. Take the proper steps and precautions to clean, dispose or change the filter media. Use Proper Protective Safety Equipment (PPE), it is recommended to wear a respirator while working with filters, in the Cyclonic Separator enclosure, or in/around the collection/discharge area.

*****ALWAYS following OSHA's State and Federal Guidelines.**

INSTRUMENT PANEL PICTURE – WITH EXPLANATIONS



- A.) Magnehelic Gauge** – Displays the Differential Pressure and indicates when filters should be checked for cleaning purposes. When the indicator reaches **FOUR** (4) the filters will require filter pulsing. Based on the application and depending on equipment usage, the filter pulsing function should be used at least once daily.
- B.) Air Pressure Gauge** – The air is preset at factory, regulated at 80-PSI max.
- C.) Filter Pulsing Button** – It is recommended when Filter Pulsing, to use this function two to three (2-3) times. Do this by pushing the filter pulsing button “IN” (while the equipment is on) allow a second then release button, then repeat this step two to three (2-3) times.
- D.) Key Ignition** – OFF position shuts down equipment after engine has been throttled down. ON Position allows for air compressor and filter pulsing operations to continue without having the engine running. START position allows engine to turn on after choked.
- E.) Air Compressor Switch** – Turns the air compressor ON and OFF, for filter pulsing.
- F.) Throttle Control Knob**–

Start Up (Choke Feature): Rotate Throttle Control knob (CCW) all the way to the left, this will allow choke lever on engine to move into appropriate position needed to start up engine.

RPM Adjustments: Maximum RPM can be achieved by rotating throttle control knob (CCW) to the left position. Rotate to the right (CW) will lower RPM'S.

Shut Down: Rotate throttle control knob to the right (CW) to power engine down. **It's important to remember this does not shut-down the portable dust collector unit's power. The Key Ignition switch will have to be in the OFF position.

2.2 OPERATING THE PORTABLE DUST COLLECTOR

After the initial set-up has taken place (**refer to SECTION 2.1 INITIAL START-UP PROCEDURES**) The Portable Dust Collector is ready for operations.

- Rotate throttle control knob all the way to the left (CCW), this will choke the engine.
- After engines been choked, turn the key ignition switch to the START position to initiate start-up of the Portable Dust Collector equipment.
- The equipment is now immediately operating.

Important Operations Information:

Monitor the Magnehelic gauge indicator during operations. When the indicator reaches **FOUR INCH WG** (4" WG) the filters will require filter pulsing. Based on the application and depending on equipment usage, the filter pulsing function should be used at least once daily.

When ready for filter pulsing; turn the air compressor switch to the ON position. This will turn the on-board air compressor on. The air is preset at factory, regulated at 80-PSI max.

It is recommended when Filter Pulsing, to use this function two to three (2-3) times. Do this by pushing the filter pulsing button "IN" (while the equipment is on) allow a second and let go of button, then repeat this step two to three (2-3) times.

Based on the application and depending on equipment usage, after filter pulsing, the debris drawer underneath the filter cartridge and the Spark Arresting Filter should be checked and/or cleaned out at least once a day.

This equipment is designed with a flexible hose and can be manipulated by the operator for quick and easy adjustments while allowing continuous productive work.

WARNING! Keep hand, fingers, and any obstructions away from the hose inlet while unit is operational.

 <p>Risk of serious injury. Do not clean, service, or adjust any machine unless all power is secure. Follow written lockout & tagout procedures.</p>	<p style="text-align: center;"><u>WARNING!</u></p> <p>NEVER start any kind of maintenance on The Portable Dust Collector System unless ALL power to the equipment has been shut down.</p>
--------------------------------------------------------------------------------------------------------------------------------------------------------------------------------------------------------------------------------------------------------	----------------------------------------------------------------------------------------------------------------------------------------------------------------------------------------------------------------

Operation of Cyclonic Separator 55-Gallon Drum:



*** Its recommended to wear respirators whenever dealing with used Filter Cartridges or when changing out Collection Drums.

To remove as much dust from the filter area, it is recommended to use the filter pulsing function. When Filter Pulsing, it is recommended to use this function two to three (2-3) times. Do this by pushing the filter pulsing button "IN" (while the equipment is on) allow a second and let go of button, then repeat this step two to three (2-3) times.

- This will draw any extra dust collected in the filter housing. The dust will be recirculated back into the cyclonic separator and into the 55-gallon drum.
- Once the 55-gallon drum is full, turn Portable Dust Collector OFF by rotating the throttle control knob right (CW) to power engine down then the key ignition switch will have to be switched to the OFF position. **SEE SECTION 2.3 STANDARD SHUTDOWN PROCEDURE.**
- Raise the drum cover by applying pressure down on the drum cover handle(s) there are two (2) and pull out the latching mechanism/ safety catch so the lid can lift and unlock off the drum opening.

Drum Cover Locking Handle:

Shown "UP in LOCKED" position.



Shown "DOWN in UNLOCKED" position.



- Remove, cover, and dispose of contents in drum.
- Install empty drum under Cyclonic Separator.
- When 55-Gallon drum is lined up to the Cyclonic Separator, PULL the drum cover handle(s) there are two (2) and pull up the latching mechanism/ safety catch so the lid can lower down and lock on the drum opening.
- Repeat when needed.

2.3 STANDARD SHUTDOWN PROCEDURE

- Rotate throttle control knob to the right (CW) to IDLE position.
- When ready for filter pulsing; turn the air compressor switch to the ON position. This will turn the on-board air compressor on. The air is preset at factory and will need to be regulated at 80-PSI max.
- It is recommended when Filter Pulsing, to use this function two to three (2-3) times. Do this by pushing the filter pulsing button "IN" (while the equipment is on) allow a second and let go of button, then repeat this step two to three (2-3) times.
- Rotate throttle control knob to the right (CW) to power engine down.

***It's important to remember this does not shut-down the portable dust collector unit's power. The Key Ignition switch will have to be in the OFF position.*

- When ready to completely ready to shut down the portable dust collector's power the key ignition switch will need to be in the OFF position.
- Based on the application and depending on equipment usage, after filter pulsing, the debris drawer underneath the filter cartridge should be checked and/or cleaned out at least once a day.
- Check and/or clean the spark arrestor filter daily. This is made of a metal mesh that is easily washable with water.
- Make sure all equipment and it components are secured properly.
- Empty Contents of 55-Gallon Drum.
- Empty Contents of Dust and Debris Drawer.
- Once these procedures are done The Portable Dust Collector will be ready for moving or transporting.

**** NOTE ****

Key Ignition – OFF position shuts down equipment after engine has been throttled down. ON Position allows for air compressor and filter pulsing operations to continue without having the engine running. START position allows engine to turn on after choked.

Throttle Control Knob–

Start Up (Choke Feature): Rotate Throttle Control knob (CCW) all the way to the left, this will allow choke lever on engine to move into appropriate position needed to start up engine.

RPM Adjustments: Maximum RPM can be achieved by rotating throttle control knob (CCW) to the left position. Rotate to the right (CW) will lower RPM'S.

Shut Down: Rotate throttle control knob to the right (CW) to power engine down. ****It's important to remember this does not shut-down the portable dust collector unit's power. The Key Ignition switch will have to be in the OFF position.**

⚠ DANGER



Risk of serious injury.
Do not clean, service, or adjust
any machine unless all power is
secured. Follow written lockout &
tagout procedures.

WARNING!

NEVER start any kind of maintenance on The Portable Dust Collector System unless **ALL** power to the equipment has been shut down.

Disconnect and lock out power **PRIOR** to adjusting, entering, servicing and/or performing any form of maintenance to The Portable Dust Collector Equipment. Failure to do so could result in serious personal injury, property damage and/or death.

SECTION 3: MAINTENANCE AND TROUBLESHOOTING INSTRUCTIONS

3.1 ROUTINE MAINTENANCE

The Portable Dust Collector System provides easy maintenance and helps to insure a safer and cleaner working environment.

Look over The Portable Dust Collector System prior to start-up, watching for anything that indicate equipment issues. It is recommended, however; to carefully continue observing the equipment during operations and if an issue arises to discontinue operations immediately.

Daily:

- Prior to actual operation, operators must be familiar with starting and stopping The Portable Dust Collector System.
- Check for air leakage on components and fix if needed.
- Visually inspect the general appearance of the fan outlet damper for dust emissions. If dust is visible check condition of filter cartridges for holes or loose fit.
- Pay attention to equipment, watching for any unusual vibrations, noise or any operating temperatures exceeding the maximum specs for your equipment.
- Make sure all hardware and connections are securely fastened.
- Make sure there are no obstructions around inlet and outlet connections.
- Check Oil Level. SAE 10W-30 is recommended for general use.
- Make sure there's enough gasoline. It is recommended to use UNLEADED GASOLINE – Pump octane rating 86 or higher.

Weekly or Periodic:

- Inspect fan housing for foreign material, drain and/or remove if needed. **(Refer to FAN MAINTENANCE AND TROUBLESHOOTING MANUAL)**
- Inspect bearings and handle control on damper. **(Refer to FAN MAINTENANCE AND TROUBLESHOOTING MANUAL)**
- Make sure moisture is kept out of the air system and filter cartridge area.
- Check Fluids **(Refer to GASOLINE ENGINE MAINTENANCE AND TROUBLESHOOTING MANUAL.)**
- Check access door and collection area for possible leaks, gasket condition corrosion, or build up.

WARNING! Prior to performing any maintenance or servicing to The Portable Dust Collector, lockout and tagout any and all power to the equipment. Failure to do so could result in serious personal injury, death, or property damage.



Maintenance References:

Portable Dust Collector critical component informational references:

- Engine Information (**Refer to GASOLINE ENGINE MAINTENANCE AND TROUBLESHOOTING MANUAL.**)
- Fan Information (**refer to FAN MAINTENANCE AND TROUBLESHOOTING MANUAL.**)

WARNING! NEVER start or operate this equipment without the proper safety guards or protective parts in place. Failure to do so could cause serious personal injury, death, and/or property damage.

WARNING! ALWAYS disconnect and lockout-tagout power PRIOR to servicing or performing any and all maintenance on The Portable Dust Collector Equipment. Failure to do so could result in serious personal injury, death and/or property damage.



WARNING! ONLY authorized and trained personnel should open the electrical enclosure. Use caution, electric shock can cause serious personal injury, death and/or property damage.



WARNING! Fans are designed to work by creating suction and air pressure which can be hazardous, NEVER stand directly in front of the inlet(s) and/or outlet(s) while unit is on and operating.

- **Inlet-** Is an opening or entrance for intake. Personnel or solid objects in close proximity to a fan inlet can be overcome by the created intake suction, and drawn into the fan.
- **Outlet-** Is an opening, or exit through which something is let out. Personnel in close proximity to a fan outlet can be subject to debris become dangerous projectiles upon being exhausted out.

WARNING! NEVER operate, service, perform maintenance, or attempt to touch fan with guards removed. Fan blade can cause serious personal injury, death and/or property damage.



WARNING! NEVER operate the fan with a non-ducted inlet and/or outlet. If the blower inlet and/or outlet is non-ducted, it is the user's responsibility to install an inlet and/or outlet guard.

WARNING! Even when the power supply is locked out, fans may cause injury or damage if the impeller is subject to "wind-milling," which is the fan blade and drive components turning due to a draft system. To guard against this hazard, secure fan blade, allowing no rotational movement.

3.2 MAINTENANCE SCHEDULE

PDC Maintenance Schedule:		Frequency						
Service		Daily	Weekly	Monthly	3 Months or 250 Hours	6 Months or 500 Hours	1 Year or 1000 Hours	2 Year or 2000 Hours
Symbols Used: (*)=Initial Break-In 100 Hours, A=Adjustment, C=Check, R=Replace/Renew								
Skid	Locking Casters-locked, Slide gate Valves Closed, Empty Collection Cone, Manual Damper Closed, Inlet Hose Connections	Start-Up or Shutdown Inspection						
Gasoline Engine	Throttle Control Knob	C						
	Fan, Cooling	C			C			
	Mounting Hardware			C				
	Check Oil	C						
	Check Gasoline	C						
Manual Damper	Grease -Zerk Points				R			
	Linkage and Levers					C		
Centrifugal Fan	Fan Housing Drain	C						
	Exhaust No Obstructions			C				
	Vibration Mounts		C					
	Mounting Hardware			C				
	Fan Wheel						C	
	Shaft Seal						C	
Filtering System	Rubber Fan Connection						C	
	Fan Discharge -Dust	C						
	Dust Collector Cartridges			C				
	Magnehelic Gauge Filter	C						
Electrical System	Empty Dust & Debris Drawer	C						
	Instrumentation	C						
Cyclonic Separator	Battery	C						
	Discharge Opening	C						
	Cyclonic Separator Empty	C						
	55-Gallon Drum Empty	C						

3.3 FILTER CARTRIDGE REMOVAL AND INSTALLATION

The Portable Dust Collector System should be placed in a safe and accessible position to easily access the cartridge area. Also use the appropriate personal protective equipment when removing used cartridges. Follow OSHA, state, and federal guidelines.

- Open access door by pulling out handles and rotating clockwise or counter-clockwise. May need to use keys provided doors can also be locked.
- The access door will give access to one (1) filter row of two (2) filters, the stainless-steel spark arrestor filter, the filter Engagement Handle and the dust and debris drawer.

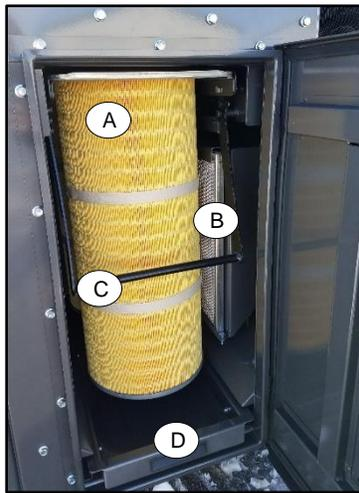

<u>Key</u>	<u>Identification</u>	<u>Remarks</u>
A	Filter Cartridge	(2) UX Nana Fiber Media, Fire Retardant, MERV 15
B	Stainless Steel Spark Arrestor Filter	Metal Mesh Washable Prefilter
C	Filter Engagement Handle	LIFT-UP when Removing Any Filter
D	Dust and Debris Drawer	Removable

- Raise the filter engagement handle to the top of the door opening. This will lower the filter rack and the cartridges can be slide out to the door opening. (open position)
- Once the cartridges are slid out they can be disposed of properly.
- At this time, its recommended to check, empty and/or thoroughly clean out the spark arrestor filter, debris drawer and the filter enclosure.

NOTE: When changing out the filter cartridges the rectangular flange will only go inside the filter track one way. Make sure each cartridge stays inside the track and that the rectangular flange hits the next without riding on top. Improper seating or positioning of the cartridge will make for sealing issues and potential dust discharge.

****It's recommended to wear respirators whenever dealing with used Filter Cartridges****

- When installing the new filter cartridge carefully place the square filter flange on the filter cartridge track and slide in until tight against the end. Then repeat as needed.
- Make sure to double check all cartridges and that the engagement handle is in the CLOSED position.
- Inspect gaskets on access doors.
- Inspect all linkage and filter racks.
- Close doors, lock if necessary.



****It's recommended to wear respirators whenever dealing with used Filter Cartridges****

**Always use proper protective equipment when operating equipment. Hearing protection, safety glasses, gloves, and respirator are recommended. Follow OSHA, State and Federal guidelines*

3.4 TROUBLESHOOTING

EXCESSIVE VIBRATION OF EQUIPMENT

- Check for loose or missing vibration mounts. Tighten or replace if needed.
- Check for loose or missing hardware. Tighten or replace if needed.
- Check for loose or excessive wear on fan wheel. Tighten or replace if needed.

EQUIPMENT WILL NOT START

- Check engines Gas and/or Oil levels. Add and/or change if needed.
- Check if the throttle control knob is choked, rotate all the way to left (CCW)

EQUIPMENT WILL NOT GENERATE AIR FLOW

- Verify Fan Wheel is rotating.
- Check Cyclonic Separator inlet screen for foreign material or blockage.
- Check outlet screen for foreign material or blockage.
- Make sure inlet and outlet duct hoses are clear. Check for foreign material or blockage.

** If experiencing other problems, please contact the manufacturer for further assistance.

3.5 TECHNICAL SUPPORT AND CONTACT INFORMATION



INDUSTRIAL VACUUM EQUIPMENT CORP.
N7959 BIRCH ROAD
IXONIA, WI 53036
1-800-331-4832
www.industrialvacuum.com

SECTION 4: SPECIFICATIONS AND OPTIONAL EQUIPMENT

4.1 EQUIPMENT DATA

The 2500 PDC Model Dust Collector System HAS the following Standard Equipment:

- Standard Equipment Options
- 8.9 HP Gasoline Honda Engine, Direct Drive
- 2500 CFM @ 8" SP Cincinnati Blower, HDBI-120 Fan
- 12VDC, 5.3CFM Heavy Duty Air Compressor
- (2) UX NANA Fiber Media, Fire Retardant, MERV 15
- (1) Carbon Odor Exhaust Filter
- (1) Stainless Steel Filter, Spark Arrestor – with Washable Metal Mesh
- Manual Push Button Cartridge Pulse Jet Cleaning
- 22" Dia. Cyclone Separator, 55-Gallon Drum
- (2) Lockable Swivel Caster Wheels
- (2) Rigid Caster Wheels
- Dust & Debris Drawer
- Magnehelic Gauge
- Epoxy Primer and Polyurethane Enamel Top Coat
- 12 Gauge Carbon Steel Construction

4.2 OPTIONAL ACCESSORIES

- Auto Cartridge Pulse Jet Cleaning
 - Single Phase Electric Motor, 115/230V
 - Lifting Eyes
 - Fork Lift Pockets
 - HEPA Filters, 99.97% @ 0.3 Micron
 - Discharge Silencer
 - Inlet or Outlet Damper
 - Explosion Proof Motor and Controls
 - AMCA type "A" or "B" Fan Construction
 - Ducting and Hose Accessories
-

SECTION 5: MAJOR COMPONENTS AND REFERENCE INFORMATION

5.1 MOTOR

DESCRIPTION: 8.9HP Gasoline Engine
MANUFACTURER: Honda

5.2 CENTRIFUGAL FAN

DESCRIPTION: 2500 CFM @ 8" SP, HDBI-120
MANUFACTURER: Cincinnati Fan

5.3 ELECTRICAL COMPONENTS

DESCRIPTION: 12V DC, 5.3 CFM Heavy Duty Air Compressor
MANUFACTURER: Klutch

DESCRIPTION: Air Regulator, ¼ NPT, 0-125 PSI
MANUFACTURER: Midwest Control Devices

DESCRIPTION: 40 A/H, 12 VDC Battery
MANUFACTURER: Power Sonic

**SECTION 6:
WARRANTY AND SERVICE NOTES**

**INDUSTRIAL VACUUM EQUIPMENT CORP.
LIMITED WARRANTY**

Seller warrants each new product to be free from defects in material and workmanship under normal use and maintenance as herein described. This warranty does not apply to commercial items manufactured by others (Cincinnati fans, HONDA, etc.), which are covered by existing warranties of the representative manufacturers thereof. Seller's sole obligation under this warranty shall be limited to repairing, replacing or allowing credit for, at Seller's option, any part which under normal and proper use and maintenance proves defective in material or workmanship within twelve (12) months after delivery to Buyer. In the event of defects developing within that period, the Seller will furnish, F.O.B. its plant, without charge, parts required to replace material found defective. Beyond this, the Seller assumes no responsibility.

This warranty is in lieu of all other warranties (except of title), expressed or implied, and there is not an implied warranty of merchantability or fitness for a particular purpose. In no event shall Seller be liable for consequential or special damages.

Used products are sold on an "as is" basis and there is no implied warranty of merchantability or of fitness for a particular purpose, unless otherwise expressly stated on the face of this form.

**SECTION 7:
SPARE PARTS LIST**

PORTABLE DUST COLLECTOR PARTS CAN BE REPLACED BY THE MANUFACTURER.



<u>QUANTITY</u>	<u>PART</u>	<u>PART NUMBER</u>
1	THROTTLE CONTROL KNOB (CABLE W/ FRICTION LOCK)	PC50155
1	"FILTER PULSE" BUTTON	PP10048
2	RIGID CASTER WHEEL	MC96000
2	LOCKABLE SWIVEL CASTER WHEEL	MC96001
1	1" DIAPHRAGM	PP19110
1	DIAPHRAGM REBUILD KIT	PP20008
2	FILTER CARTRIDGES, MERV 15	PP11050
1	SPARK ARRESTOR FILTER	PP10050
1	CARBON ODOR FILTER	PP10052

#PDC-25-041825 UNIT SCHEMATIC #1

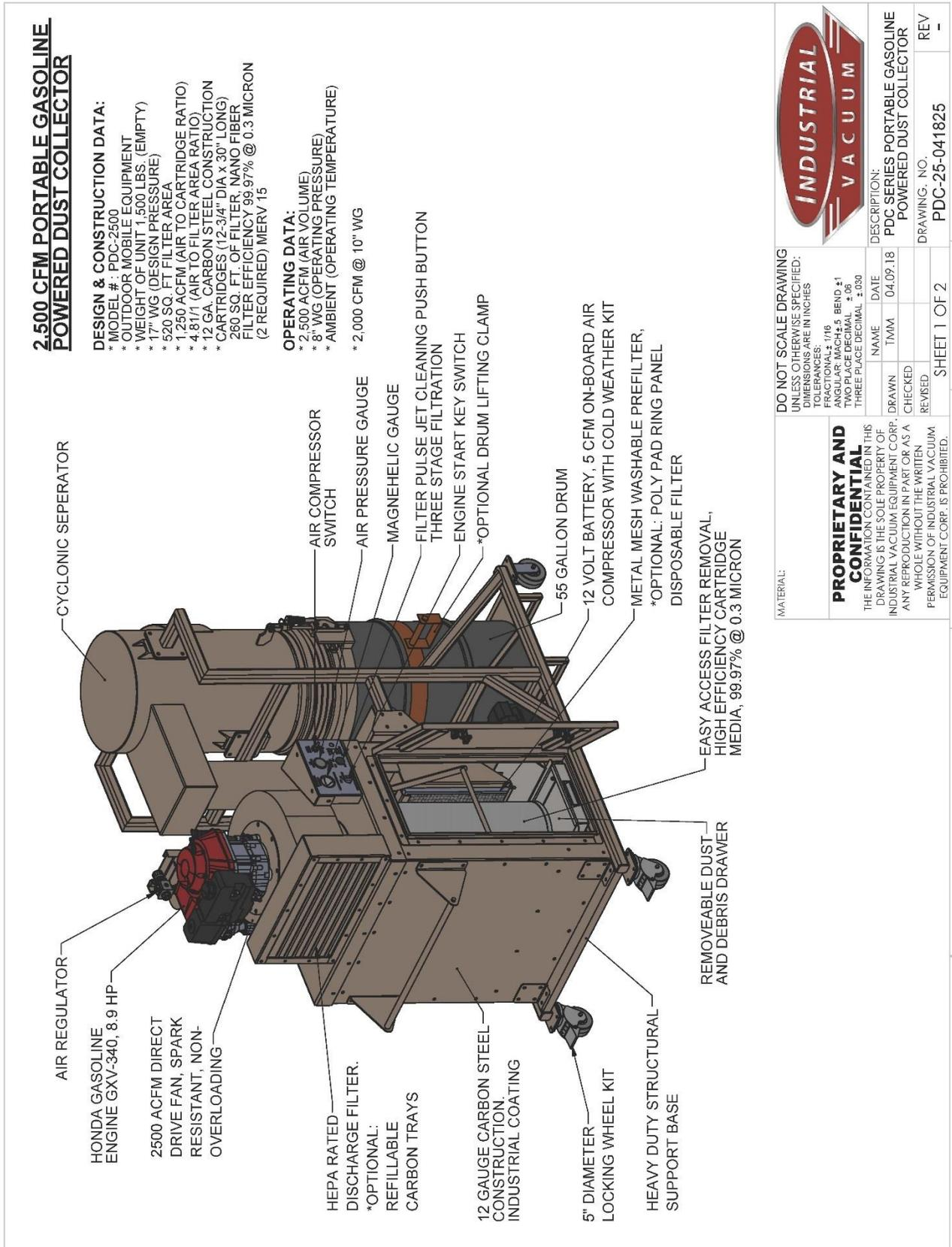

<p>INDUSTRIAL VACUUM</p>		<p>DO NOT SCALE DRAWING UNLESS OTHERWISE SPECIFIED: DIMENSIONS ARE IN INCHES</p> <p>FRACTIONAL: 1/16 BEND ±1 TOLERANCES: 1/8 ±0.015 TWO PLACE DECIMAL ±.02 THREE PLACE DECIMAL ±.030</p>	<p>DESCRIPTION: PDC SERIES PORTABLE GASOLINE POWERED DUST COLLECTOR</p>
<p>NAME</p>	<p>DATE</p>	<p>DRAWN</p>	<p>REV</p>
<p>TMM</p>	<p>04.09.18</p>	<p>CHECKED</p>	<p>DRAWING. NO. PDC-25-041825</p>
<p>REVISED</p>	<p>SHEET 1 OF 2</p>	<p>2</p>	<p>1</p>

PROPRIETARY AND CONFIDENTIAL

THE INFORMATION CONTAINED IN THIS DRAWING IS THE SOLE PROPERTY OF INDUSTRIAL VACUUM EQUIPMENT CORP. ANY REPRODUCTION IN PART OR AS A WHOLE WITHOUT THE WRITTEN PERMISSION OF INDUSTRIAL VACUUM EQUIPMENT CORP. IS PROHIBITED.

#PDC-25-041825 UNIT SCHEMATIC #2

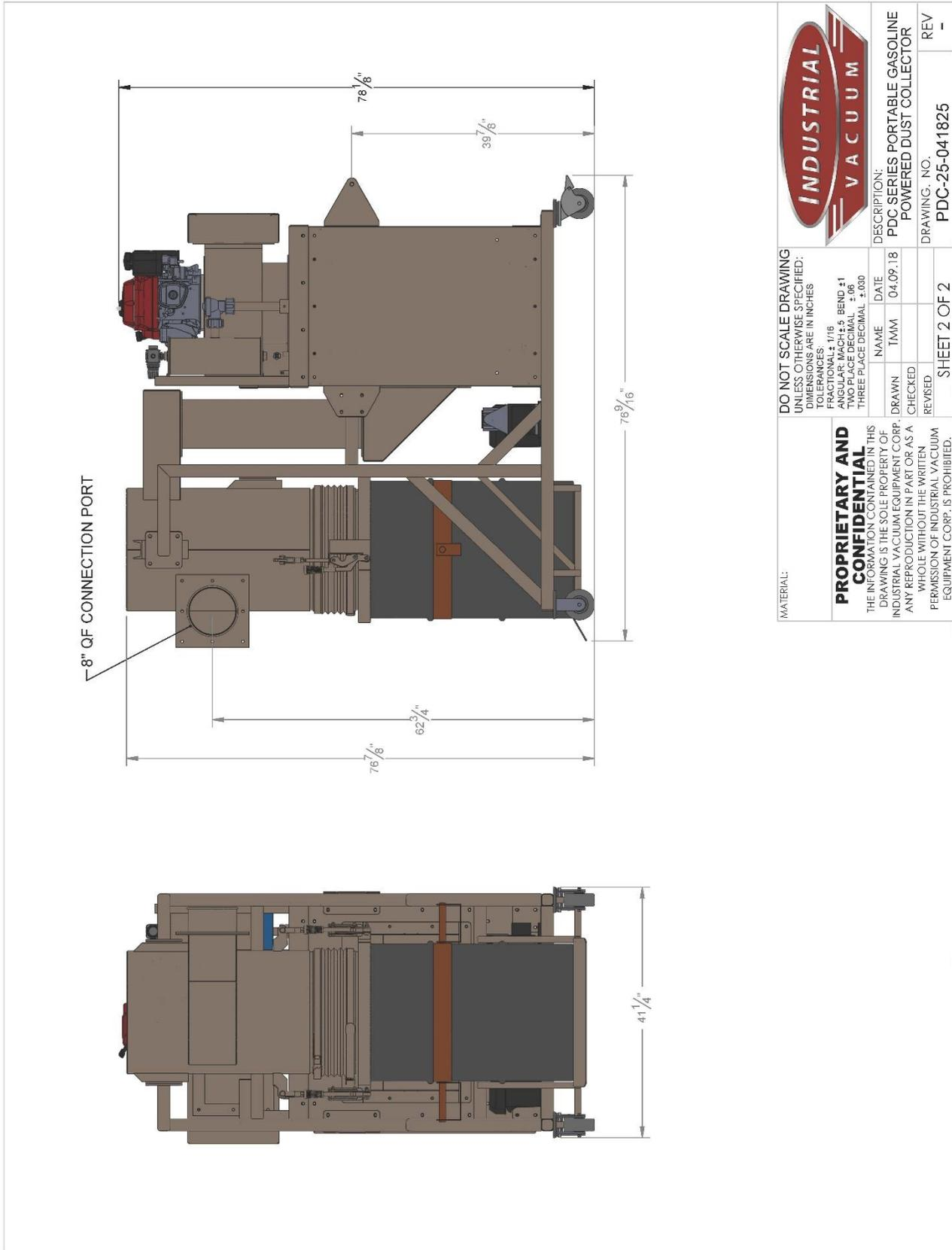

<p>DO NOT SCALE DRAWING UNLESS OTHERWISE SPECIFIED: DIMENSIONS ARE IN INCHES TOLERANCES: FRACTIONAL: 1/16 DECIMAL: .005 HOLE DIA: .005 TWO PLACE DECIMAL: .01 THREE PLACE DECIMAL: .005</p>	<p>INDUSTRIAL VACUUM</p>	<p>DESCRIPTION: PDC SERIES PORTABLE GASOLINE POWERED DUST COLLECTOR</p>
	<p>DATE: 04.09.18 DRAWN: TMM CHECKED: [] REVISED: []</p>	<p>DRAWING NO.: PDC-25-041825 REV: -</p>
<p>MATERIAL: PROPRIETARY AND CONFIDENTIAL THE INFORMATION CONTAINED IN THIS DRAWING IS THE SOLE PROPERTY OF INDUSTRIAL VACUUM EQUIPMENT CORP. ANY REPRODUCTION IN PART OR AS A WHOLE WITHOUT THE WRITTEN PERMISSION OF INDUSTRIAL VACUUM EQUIPMENT CORP. IS PROHIBITED.</p>		<p>SHEET 2 OF 2</p>

1
2
3
4
5

#PDC-25-041821 WIRING SCHEMATIC

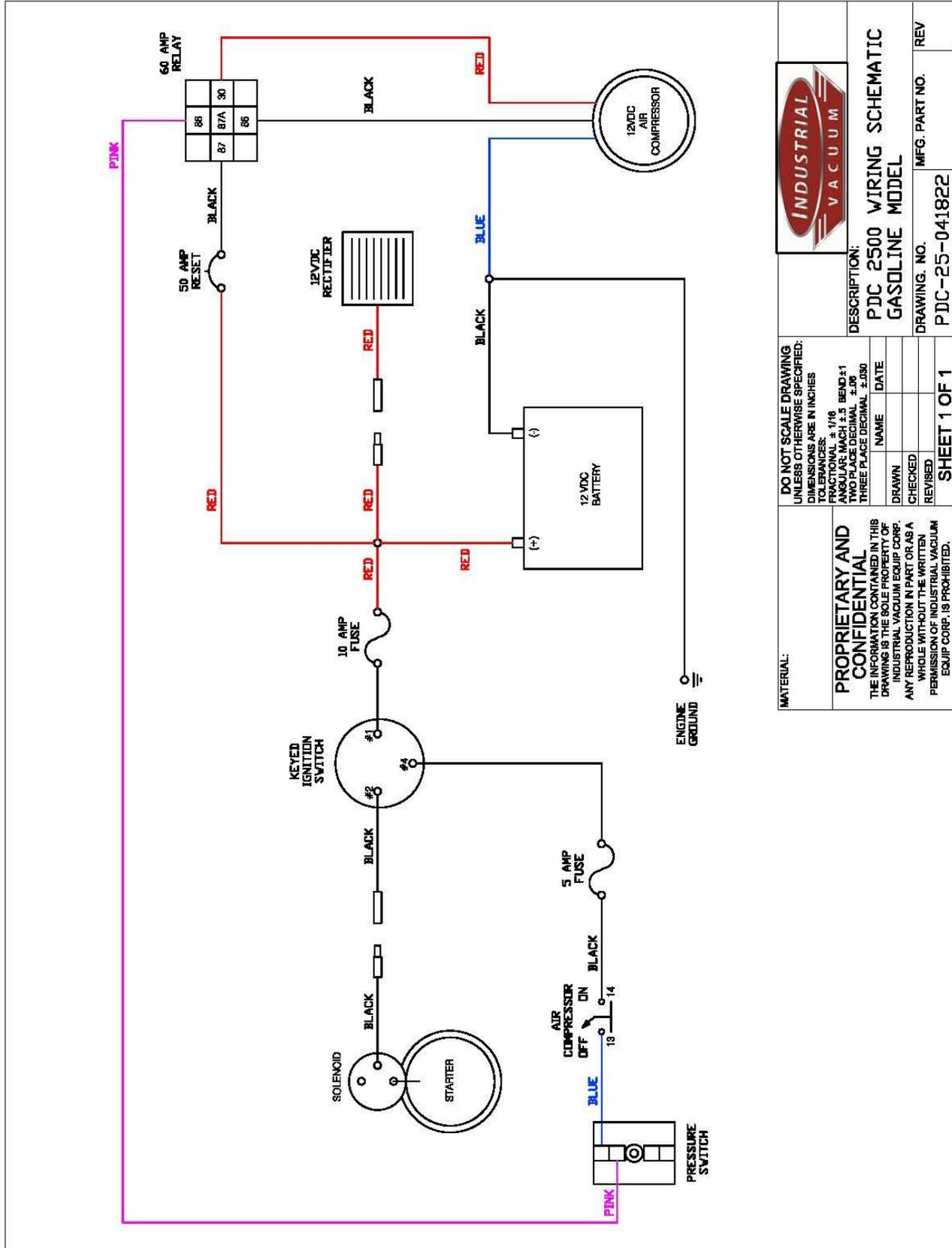

<p>INDUSTRIAL VACUUM</p>	<p>DESCRIPTION: PDC 2500 WIRING SCHEMATIC GASOLINE MODEL</p>	DRAWING NO.	MFG. PART NO.	REV
		PDC-25-041822		
<p>DO NOT SCALE DRAWING UNLESS OTHERWISE SPECIFIED: DIMENSIONS ARE IN INCHES TOLERANCES: FRACTIONAL ± 1/16 ANGULAR MATCH ± 0.5 BEND ± 1 HOLE SIZE DECIMAL ± 0.00 THREE PLACE DECIMAL ± 0.000</p>		DRAWN	NAME	DATE
<p>PROPRIETARY AND CONFIDENTIAL THE INFORMATION CONTAINED IN THIS DRAWING IS THE SOLE PROPERTY OF INDUSTRIAL VACUUM EQUIP CORP. ANY REPRODUCTION IN PART OR AS A WHOLE WITHOUT THE WRITTEN PERMISSION OF INDUSTRIAL VACUUM EQUIP CORP. IS PROHIBITED.</p>		CHECKED		
<p>MATERIAL:</p>		REVISED		
<p>SHEET 1 OF 1</p>				